



Aquatic Consulting Services

356 Sumner Ave. • P.O. Box 1418 • Avalon • California • 90704
Santa Catalina Island • (619) 602-4435 • alison@alisonosinski.com

Boating Tip #31: Raymarine RAY230 VHF Operation

There are _____ Raymarine RAY230 VHF (Very High Frequency) radio instruments aboard. They are located _____.
The VHF antenna is installed at the top of the mast. A speaker with an adjustable volume knob is also located next to each Raymarine RAY230 VHF handset.

Prior to using the device, the breaker labeled “VHF” must be turned on at the 12 volt electrical panel. Then press the FUNC and 16/9 (POWER) keys to activate the device. Turning on the RAY230 handset at either the navigation station or the helm will also activate the device at the other location.

In addition to being a VHF radio, the RAY230 instrument is also the input / control device for several other onboard instruments. The handset can be used as a horn to produce sound signals, to provide NOAA weather information, to amplify your voice through the hailer (loud speaker), and can be used as an intercom between the cockpit and navigation station below decks.

Most of the keys on the RAY230 have both a primary and a secondary function. The primary function is activated by just pressing the appropriate key. The secondary function is activated by first pressing the FUNC key in the bottom right hand corner of the handset, then the appropriate key. Primary functions are written on the key in white. Secondary functions are written above the key in yellow.

In order to transmit, press and hold down the send PTT key on the left side of the handset, and speak into the handset. Remember to let go of the send PTT key so you can hear the response. You can hear a response through the handset, or if it is turned on, through the separate speaker.

Normally, while out sailing, radio channel 16, the international distress and safety calling channel will be selected and monitored. VHF channel number frequencies most often used by recreational boaters in the U.S., include:

Channel 9	Boat calling
Channel 12	Port operations
Channel 16	International distress and safety calling
Channel 22A	USCG and maritime safety broadcasts

Channels 24-28
Channels 84-87
Channels 68, 69, 71, 78A
Channel 72

Marine operator
Marine operator
Non-commercial communications
Non-commercial intership communications

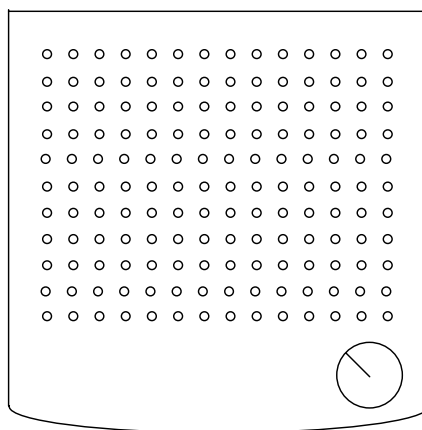
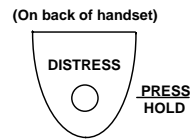
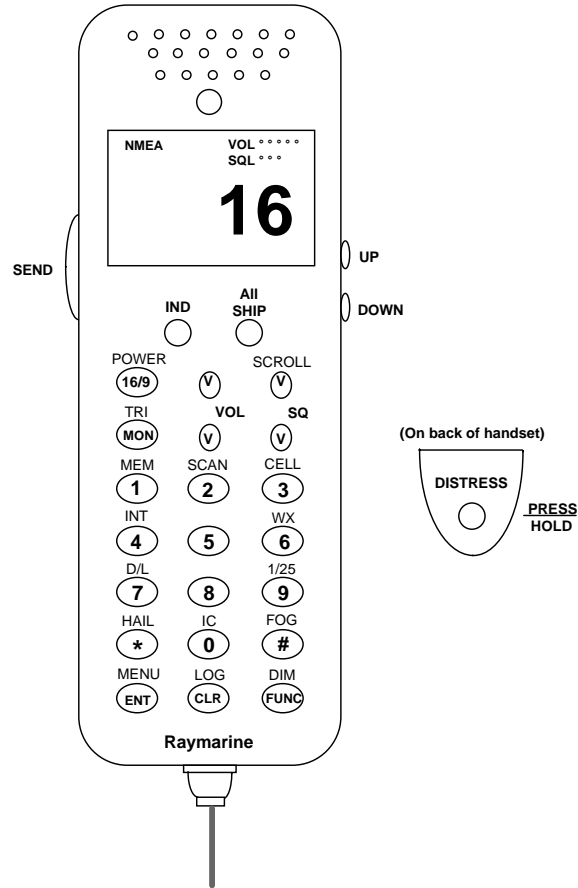

Raymarine Ray230 VHF Radio

Ray230 Handset Key Functions

White	Yellow	Primary Function	Secondary Function
16/9	POWER	Switches between channels 16 and 9 when held for 2 seconds, or between the priority channel 16 or 9, and a working channel	Powers the Ray230 on / off
MON	TRI	Activates the dual-watch monitor mode	Activates the tri-watch monitor mode
VOL		Increases / decreases handset volume	
SQ	SCROLL	Increases / decreases squelch sensitivity	Scroll through menu items
1	MEM	Inputs number 1 or a space	Adds or deletes the selected channel from memory
2	ABC SCAN	Inputs number 2 or letters a, b or c	Toggles the scan mode on / off
3	DEF CELL	Inputs number 3 or letters d, e or f	Allows the handset to operate as a cell phone. This function is not activated on MERMAID.
4	GHI INT	Inputs number 4 or letters g, h or i	Switches between US, Canadian and International frequencies
5	JKL	Inputs number 5 or letters j, k or l	_____
6	MNOWX	Inputs number 6 or letters m, n or o	Activates the NOAA weather radio. Use the up / down keys on the right side of the handset to select the desired weather channel. San Diego weather can be found on weather channel 2.
7	PQRS D/L	Inputs number 7 or letters p, q, r or s	Switches receiver sensitivity between the full distant mode and local attenuated mode
8	TUV	Inputs number 8 or letters t, u or v	_____
9	WXYZ 1/25	Inputs number 9 or letters w, x, y or z	Switches transmission power between 1 watt and 25 watts
*	HAIL	Inputs the asterisk character.	Activates the hailer horn loud speaker located on the mast below the Radome. Your voice will not be transmitted over the VHF radio.
0	IC	Inputs number 0	Activates the intercom
#	FOG	Inputs the pound character	Activates the sound signal / fog alert mode. Select the desired automatic or manual sound, then press the ENT key. Press the send key on the left side of the handset to produce the sound through the hailer.
ENT	MENU	Confirms a function	Activates the menu mode

CLR LOG	Exits current mode and reverts to previous mode. Clears numbers or letters one at a time.	Turns on / off the DSC log
FUNC DIM	Activates the secondary function mode	Press twice to activate the dimmer mode and adjust the LCD display screen backlighting
INV	Switches to the DSC individual ships call mode for activating ship-to-shore or ship-to-ship calling	
ALL SHIP	Switches to the all ships call mode to transmit urgent safety transmissions when assistance is needed, but you are not in immediate life-threatening danger. Press the ALL SHIP key. Use the SCROLL keys to select either "Safety" or "Urgency", then press the ENT key to select, then the ENT key again to reconfirm. Press the send key on the left side of the handset and the radio will automatically begin sending out the transmission on channel 70 and switch to channel 16.	
DSC DISTRESS	In an emergency, activate Digital Selective Calling. Lift the tab labeled DISTRESS on the back of the handset, then press and hold the red button for 4 seconds. DSC dSr will be displayed on the LCD screen indicating a non specified distress signal is being sent. You can also specify the type of emergency (fire, flooding, sinking...) by pressing and releasing the red button, then using the scroll keys to choose a specific emergency category, then pressing and holding the red button for 4 seconds to send.	